

SCALE: 1/1

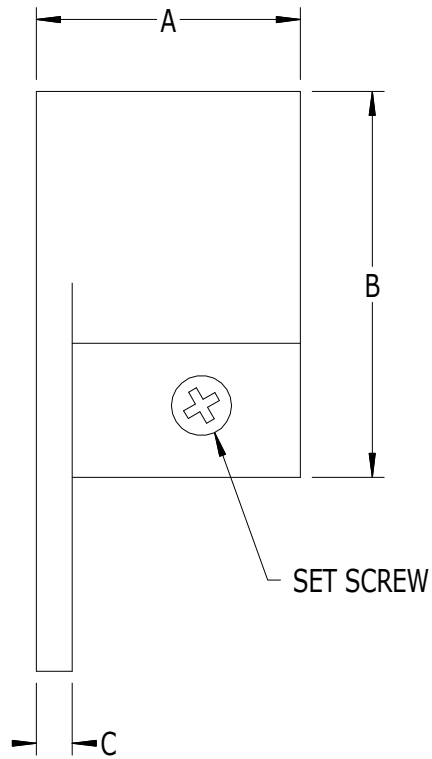

SET SCREW

SET SCREW NOTE

AFTER RAILS ARE IN PLACE DRILL 1/8" HOLE THROUGH BRACKET AND RAIL THEN INSERT #310 SCREW (#8 x 1/2" PANHEAD).

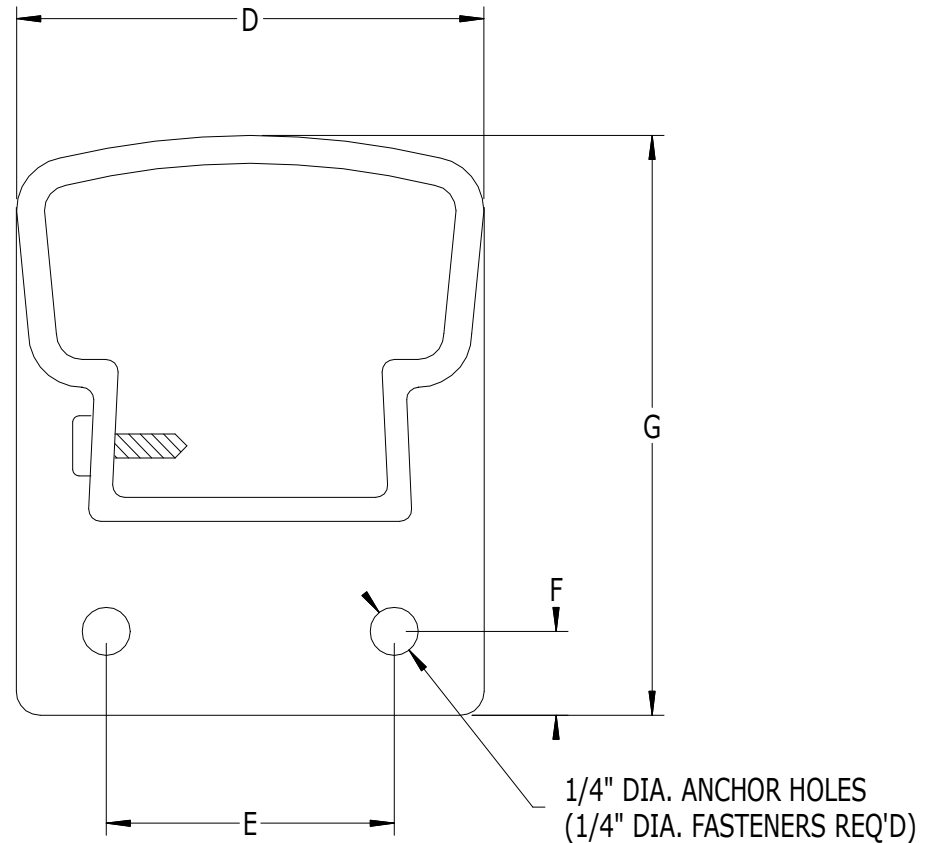

1/4" DIA. ANCHOR HOLES
(1/4" DIA. FASTENERS REQ'D)

#939T - ADJUSTABLE END BRACKET FOR #905 TOP RAIL

LABEL	A	B	C	D	E	F	G
DIMENSION	1-3/8"	2"	3/16"	2-7/16"	1-1/2"	7/16"	3"

