

Assembly of *Step* Railing

Contents of Series 950:
4 ft. Railing Package

- A-(1) Top Rail
- B-(1) Bottom Rail
- C-(11) Pickets
- D-(2) Top Vertical Swivels
- E-(2) Bottom Vertical Swivels
- F-(22) Picket Screws
- G-(4) #8 Binding Bolts
- H-(12) Self-Tapping Screws

Contents of Series 950:
6 ft. Railing Package

- A-(1) Top Rail
- B-(1) Bottom Rail
- C-(16) Pickets
- D-(2) Top Vertical Swivels
- E-(2) Bottom Vertical Swivels
- F-(32) Picket Screws
- G-(4) #8 Binding Bolts
- H-(12) Self-Tapping Screws

CAUTION Before performing any work, be sure to refer to and follow all standard industry safety precautions. In addition, Superior Aluminum Products, Inc. recommends that all installers wear appropriate protective items, such as safety glasses, work gloves, and steel toed shoes, whenever performing work on Superior Aluminum's Products.

Section Assembly

Step 1. Locate picket so picket hole aligns with hole in top rail. Drop in aluminum flathead phillips picket screw through holes and turn into top rail. **Do Not** tighten.

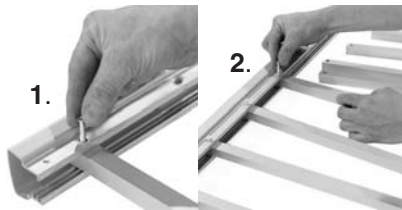

Step 2. Follow same procedure for attaching each picket to top rail.

Step 3. Locate end picket in rectangular hole in bottom rail. Align holes, then drop in aluminum flathead Phillips picket screw. Hand turn screw into bottom rail. **Do Not** tighten.

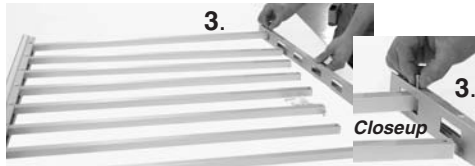

Step 4. With end picket screw in place, ease the next picket in rectangular slot (gradually one at a time) until all pickets are in place.

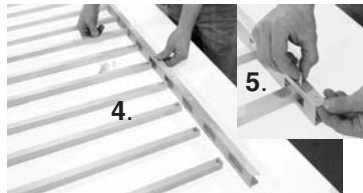

Step 5. After the last picket is in place, insert and hand tighten the picket screw to keep assembly together.

Step 6. Insert, align and hand turn all picket screws in bottom rails.



Step 7. With all picket screws in place, tighten all screws. **Do Not** overtighten. Start with lowest clutch torque setting, then gradually increase for proper torque.

Important: It is recommended that the required length of step rail (cut to fit, if required) be completed prior to starting Step 8. Refer to section titled "**Shortening a Railing Section**" and "**Determining Step Railing Length**". After railing is cut to required length, proceed to "Step 8" for installation of vertical swivels.

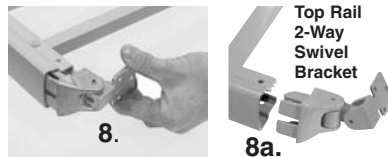

Step 8. Insert top vertical swivel or optional swivel as shown at 8a.

Step 9. Use a 13/64" diameter drill to align holes in top vertical swivel to hole in top rail. **NOTE:** It may be necessary to drill a new alignment hole in top and bottom (shortened) rails. Use the pre-drilled hole in matching cut-off end as a hole location guide.

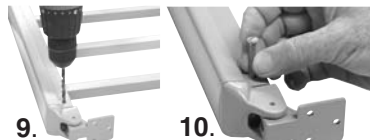

Step 10. Insert a #8 female binder bolt. Turn male binder bolt screw into female binder bolt and tighten to secure assembly together. Follow the same procedure on opposite end of top rail.

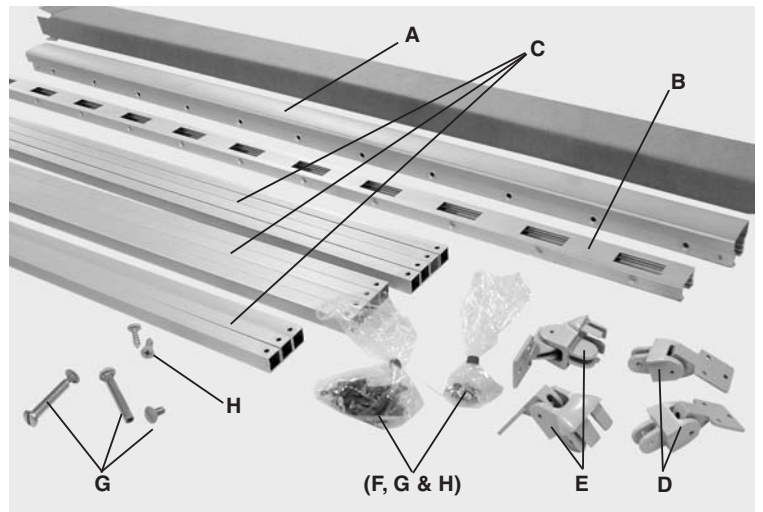

Tools Required: Tape Measure, Battery Operated Drill with adjustable torque clutch, Phillips and Flathead Screwdriver Bits, 1/8" and 13/64" twist drill Bits, (Hacksaw or Cutoff Saw-if required) Hammer, Small Square and Pencil.

Step 11. Insert bottom vertical swivel into end of bottom rail. See (11a.) for bottom 2-way swivel bracket.

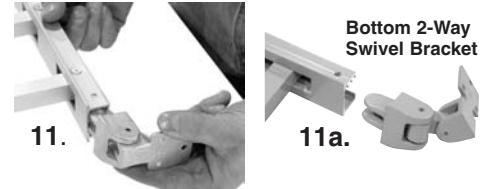

Step 12. Use a 13/64" diameter drill to align holes in bottom vertical swivel to hole in bottom rail.



Step 13. Insert a #8 female binder bolt. Turn male binder bolt screw into female binder bolt and tighten to secure assembly together. Follow the same procedure on opposite end of bottom rail.

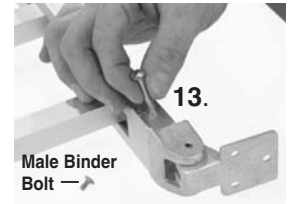

Shortening a Railing Section (If Required)

Be sure to wear Safety Glasses

When shortening a step railing section, it is imperative that the gap between last picket and post is less than 4", as shown in "**Closeup View**" below. Refer to section titled "**Determining Step Railing Length**" on opposite side of sheet. If railing shortening is required, avoid cutting (if possible) in rectangular slot on bottom rail. To shorten railing use a hacksaw or a cut-off saw. Remove any burrs from sawcut. **Important:** Do Not discard cut-off ends, since the pre-drilled hole locations can be used as a (new hole) alignment guide for "Step" 9 and 12.

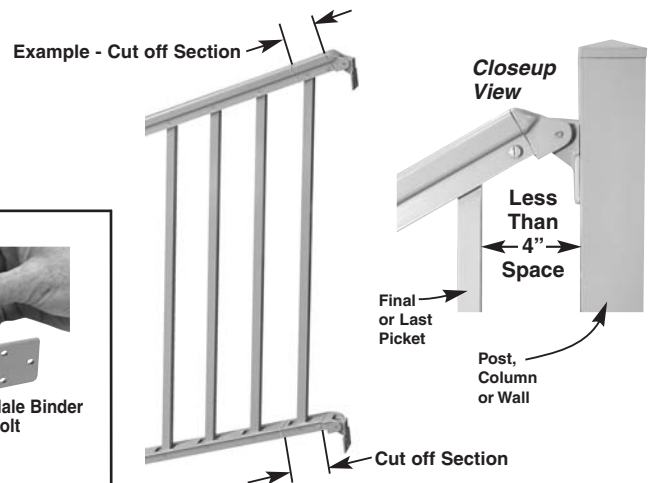

Determining Step Railing Length

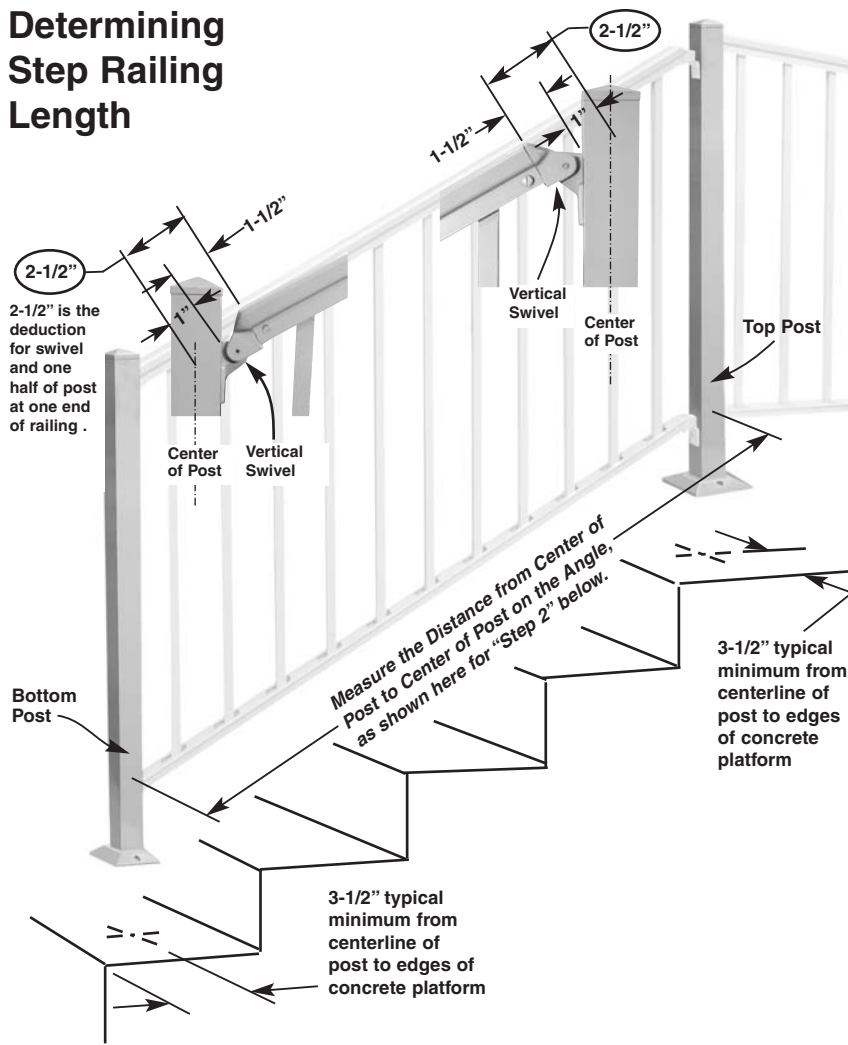

- Step 1.** As shown above, set top post and bottom post an equal distance back on steps.
- Step 2.** Measure the distance from center of top post to center of bottom post on the angle.
- Step 3.** Deduct (subtract) 5" from the measured distance taken at Step 2.

Note: The 5" represents the 2-1/2" required at each railing end, as shown above.

For Example: If measured distance from center of top post to center of bottom post is 69-1/2".

Deduct 5" from 69-1/2" (69-1/2" - 5" = 64-1/2"). The total cut length from a 6 ft. (72" lg.) step railing section should be 64-1/2".

Example: 72" (6 foot step railing section)
 - 64-1/2" (railing length required)
 = 7-1/2" (total length to cut off)

NOTE: To meet Code Requirements, it is imperative when trimming rail between the final picket and the vertical swivel (see illustration), that there be less than a 4" space.

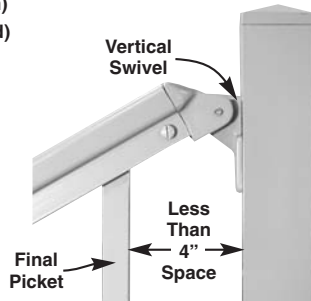

Determining Step Railing Height

The hand step railing height measured above stair thread nosings shall not be less than 34" and not more than 38" to top of top rail surface. **CHECK APPLICABLE LOCAL, STATE AND FEDERAL BUILDING CODES FOR SPECIFIC HEIGHT REQUIREMENTS.**

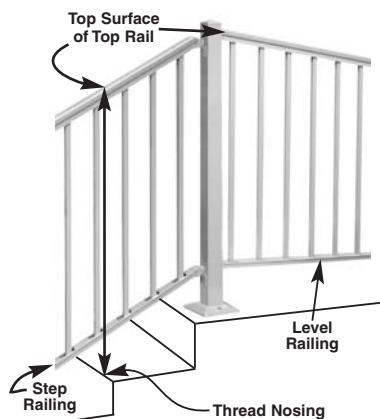

To Attach Railing To Post

Step 1. When required railing height is achieved, position post against top and bottom vertical swivels. Using holes in vertical swivel as a template, mark each mounting hole location. Mark the hole locations at top, bottom and on each rail section end. See "Note" below.

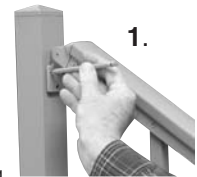

Note: Before pencil marking vertical swivelholes onto post, check that post base mounting holes are facing in opposite directions to railing sections as shown in photo at left. The reason for this is that it is easier to install post base mounting bolts. Disregard this "Note" for railing corner post.



Step 2. Drill 1/8" holes in post for mounting location of top and bottom rails.

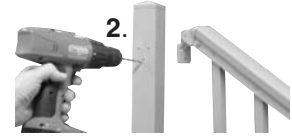

Step 3. To secure the vertical swivels to the post use (3) #8 x 3/4" stainless steel self-tapping screws (furnished) for each end bracket. Follow same procedure for the remaining three rail section ends. Note that a 6" shaft extension fitted to the phillips screwdriver bit aids in the job and helps to prevent scratching the paint.

Step 4. Locate assembled posts and railing onto final mounting position. Use the 2 post base holes as a template and mark mounting holes on platform or floor surface. **Note that the centerline of the post must be a minimum of 3-1/2" from outer edges of concrete platform.**

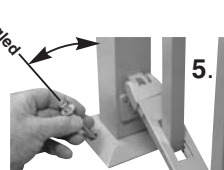
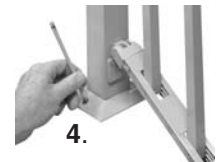

Step 5. The hole to be drilled into the mounting platform should be angled, so it is approximately perpendicular to, (or 90 degrees to) the angled, sloped post base. The diameter of the fastener used must be a minimum of 3/8". The exposed fastener and washer should be stainless steel. Two drilled holes (one on opposite sides) are required for each post. **Check with local building code office and comply with all local, state or federal requirements for post base mounting.**

Hand Rail System



Attaching wall returns or 3" wall bracket to hand rail.

Locate wall returns or 3" wall brackets in position on hand rail. Drill a 13/64" diameter hole through the assembly, then secure in place with a #8 binder bolt.



Attaching top rail hinge

Locate top rail hinge in place, then drill (4) 1/8" diameter holes (2 on each side) at locations shown. Secure top rail to top rail hinge with (4) #8x1/2" lg. screws.

