

Shortening a Railing Section

(If Required)

When shortening a Railing Section, it is **imperative** that the gap between last picket and post is less than 4". Use a hacksaw or a cut off saw. Remove any burrs from sawcut. **Important: Do Not** discard cut-off section, since the pre-drilled hole locations can be used as a new hole location alignment guide for Step 9 on opposite side of sheet.

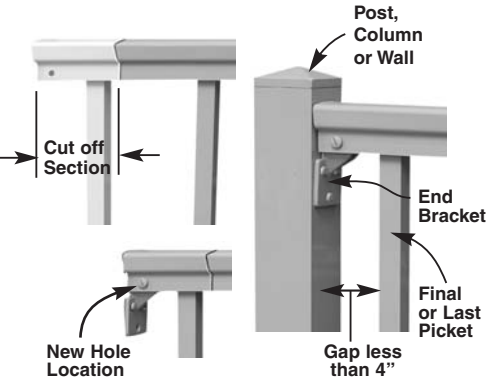

NOTE: To meet Code Requirements, it is **imperative** when trimming rail between the final picket and the end brackets (see illustration above), that there be less than a 4" space.

SERIES
950

Determining Railing Height

The **Railing Height** or distance measured from Floor to top of Top Rail surface is determined by your local area building codes. For example: A building code that requires a 36" high railing (top rail height), means that a total of 36" (inches) is required from floor (ground) to top rail surface. The bottom rail distance above ground (or floor) is 3-3/4" or less. **Important:** A sphere 4" in diameter shall **not pass** through the railing at any point.

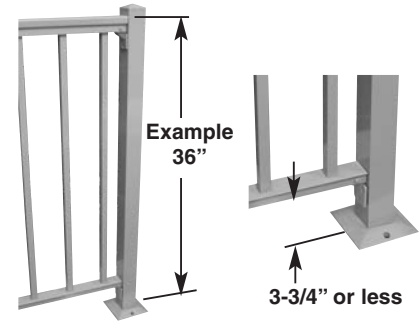

To Attach Railing To Post

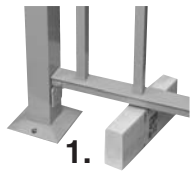

Step 1. Cut several wood spacers to prop up the railing so the top rail is at the required building code height.

Step 2. When required railing height is achieved, position post against railing end brackets. Using holes in end brackets as a template, mark each mounting hole location. Mark the hole locations at top, bottom and on each rail section end. See "Note" below.



Note: Before pencil marking end bracket mounting holes on post, check that **post base mounting holes** are facing in opposite directions to railing sections as shown in photo at left. The reason for this is that it is easier to install post base mounting bolts. Disregard this "Note" for railing corner post.

Step 3. Drill 1/8" holes in post for mounting location of top and bottom rails.

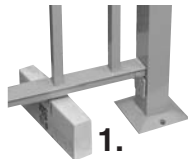

Step 4. To secure the end bracket to the post use (3) #8 x 3/4" stainless steel self-tapping screws (furnished) for each end bracket. Follow same procedure for the remaining three rail section ends. **Installation Tip:** Note that a 6" shaft extension fitted to the phillips screw driver bit aids in the job and helps to prevent scratching the paint.

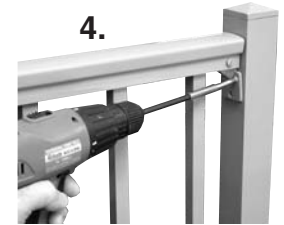

Step 5. Straight and corner sections can be pre-assembled together prior to attaching to platform or ground level.



Step 6. Locate assembled posts and railing onto final mounting position. Use the 2 post base holes as a template and mark mounting holes on platform or floor surface.

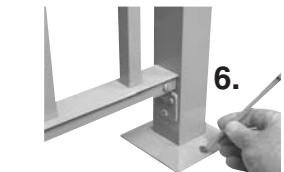

Step 7. The hole to be drilled into the mounting platform should be angled, so it is approximately perpendicular to, (or 90 degrees to) the angled, sloped post base. The diameter of the fastener used must be a minimum of 3/8". The exposed fastener and washer should be stainless steel. Two drilled holes (one on opposite sides) are required for each post. **CHECK APPLICABLE STATE, LOCAL AND FEDERAL BUILDING CODES FOR SPECIFIC FASTENING REQUIREMENTS.**

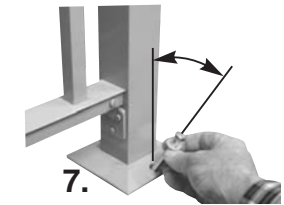

Optional Adjustable End Fittings

Attaching Adjustable End Fittings to Building Structure

Locate and slide the top rail adjustable end fitting onto top rail. Next position and slide the bottom rail adjustable end fitting onto the bottom rail. Using a 1/8" diameter drill bit, drill a hole through one side of top and bottom adjustable end fittings and through associated top and bottom rails. Then secure adj. end fittings to rails with a #8 x 01/2" self-tapping screw. Each adjustable fitting has two mounting holes for inserting 1/4" diameter stainless steel screws to secure the railing section to the building structure. **CHECK APPLICABLE STATE, LOCAL AND FEDERAL BUILDING CODES FOR SPECIFIC FASTENING REQUIREMENTS.**

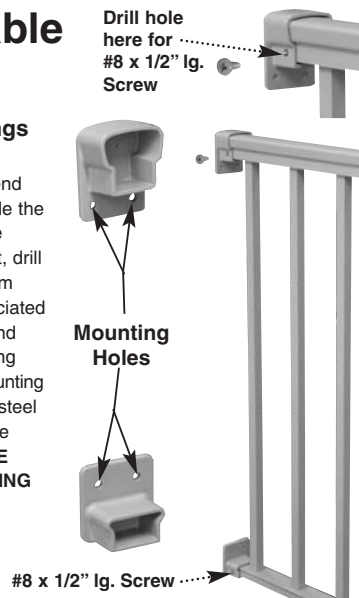

Example view of drilled mounting holes at mortar joints

Optional Wall Plate

Attaching Wall Plate to Building Structure

The wall plate is commonly used to secure railing sections to brick, stone or masonry wall structures. It allows for locating and drilling mounting holes at mortar joints. Refer to steps below for attaching wall plates.

- Step 1.** Mark mounting holes on wall plate using each end bracket as a template.
- Step 2.** Drill 1/8" holes through wall plate.
- Step 3.** Attach wall plate to end brackets using (3) #8 x 3/4" stainless steel screws.
- Step 4.** Grind or saw off any protruding screw ends.
- Step 5.** Drill (2) 9/32" holes through wall plate at mortar joint locations.
- Step 6.** Insert and tighten screws to secure railing section to wall. **CHECK APPLICABLE STATE, LOCAL AND FEDERAL BUILDING CODES FOR SPECIFIC FASTENING REQUIREMENTS.**

