

Superior

Non-Welded Aluminum
Pipe Railing

Meets OSHA, ADA and ICC Safety Criteria

SERIES
500
550



Strong, Durable and Maintenance-Free!

www.superioraluminum.com



Series 500 Pipe & Series 550 Pipe Picket Non-Welded Aluminum Pipe Railing

Meets OSHA, ADA and BOCA Safety Criteria

Superior Series 500 Pipe Railing and Series 550 Pipe Picket Railing are designed to utilize all the advantages of aluminum, where strength, durability and no-paint maintenance are key. The highest quality aluminum extrusions and castings are used with concealed fasteners to create a clean, contemporary design.

Components are easily assembled without welding by using mechanical fasteners at intersections and epoxy structural adhesive at splice joints.

Superior Pipe and Pipe Picket Railings are factory assembled and made to your exact specifications. Special curves or pipe radius can easily be fabricated to fit your needs. This results in further on-site fabrication savings and makes a practical sound investment for the budget-minded buyer.

Posts and top rails for Pipe and Pipe Picket Railings are assembled to run in continuous lengths. Not only is this system stronger than one with cast tee and cross connections, but

it also provides a continuous smooth top rail surface. Furthermore, pipe pickets are factory assembled with a tight drive-in-fit to the top and bottom rails to ensure squareness and rigidity.

Preassembled sections up to 24 feet can be shipped factory-assembled or knocked down for reassembly.

Superior Pipe and Pipe Picket Railings are available in standard heights of 32", 36", 42" and 48" and in custom heights upon request.

Finishes

The clean, contemporary design and smart, decorative finishes of Superior Pipe and Pipe Picket Railing add a distinctive touch to any building. Whether baked-on enamel, anodized or duranodic, these finishes are guaranteed to endure for years of maintenance-free beauty.



Concealed fasteners allow for a smooth surface and create a clean, contemporary design



Part Applications

Series 500 Pipe Railing

Series 550 Pipe Picket Railing

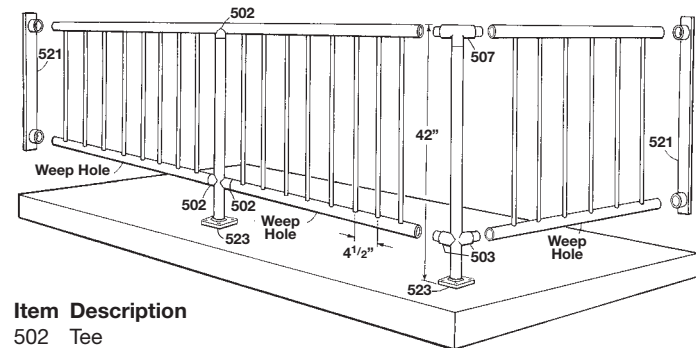
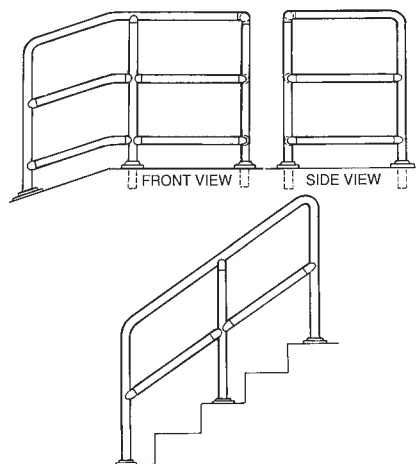

Item	Description
502	Tee
503	Corner Tee
507	90° Three-Way Elbow
521	Wall Plate with Adj. Brackets
523	Heavy-Duty Base with Post

Hand Rail System

Pipe Picket Railing Design Selections

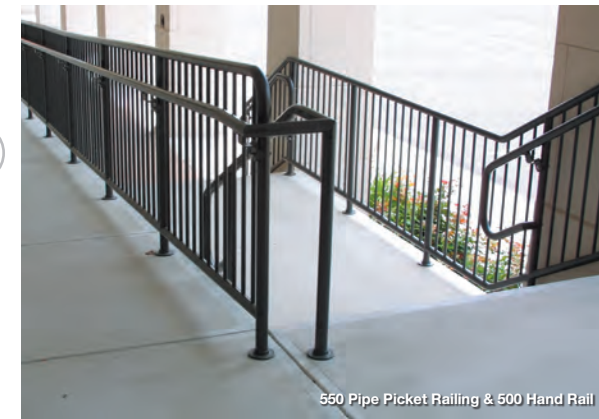
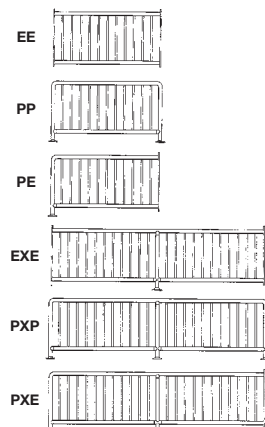

Component Parts

For Series 500 Pipe Railing & Series 550 Pipe Picket Railing

No. 5B Picket

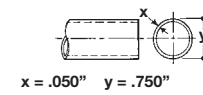

No. 500

1-1/2" Schedule 40 Pipe - 24'

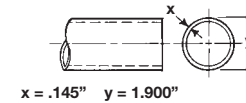

No. 501 Post (Any Type)

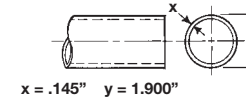

No. 502 Tee (A)

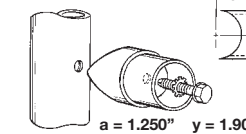

No. 503 Corner Tee (B)

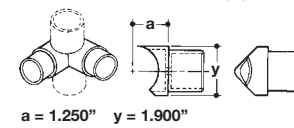

No. 504 Angle Tee (C)

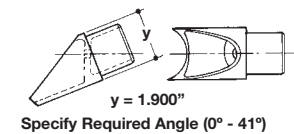

No. 505 Adj. Angle (0° - 38°)

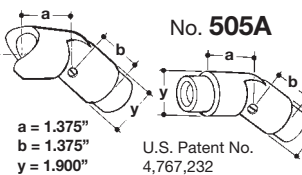

No. 506 90° Miter Elbow

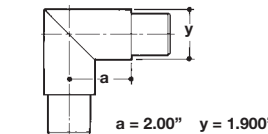

No. 507 90° 3-Way Elbow (F)

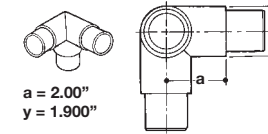

No. 508 Floor Flange (G)

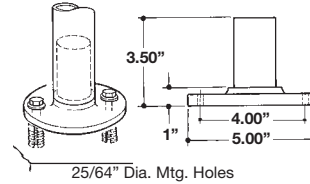

No. 509 Cover Flange (H)

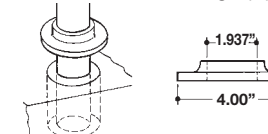

No. 510 90° Radius Elbow (I)

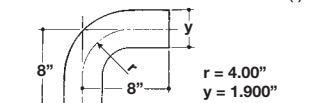

No. 511 Bottom Step Post Elbow (J)

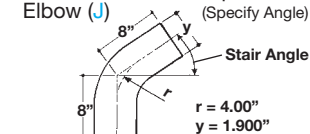

No. 512 Top Step Post Elbow (K)

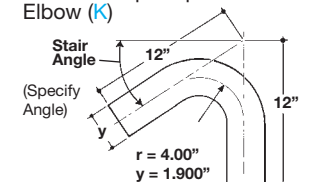

Consider the advantages:

- Strong, Durable and Functional Design
- No Painting – No Rusting
- Unlimited Design Options
- Quick & Easy Installation Without Welding
- Saves on Installation and Maintenance Labor



Plus, the possibilities for contractors, builders & architects:

- Handicap Ramps
- Condominiums
- Industrial Buildings
- Stores
- Waste Water Treatment Plants
- Nursing Homes
- Municipal Buildings
- Schools
- Office Buildings
- Motels
- Churches
- Hospitals
- Factories
- Amusement Parks
- Restaurants
- Swimming Pools
- Cafeterias

Easy Assembly and Installation! *No welding required.*

Railing Splices

Railing splices are designed for a tight press fit and must be compressed with a pliers to permit them to slip into the pipe. The areas to be joined should be cleaned thoroughly. Mix adhesive according to manufacturer's directions. Mix only enough that you can use within 1/2 hour. Apply adhesive to inside surface of pipe. Compress splice sleeve with a pliers, then slip into the pipe. Wipe off excess adhesive after components are properly joined. The areas connected together should be left undisturbed for eight hours, longer in cold weather.

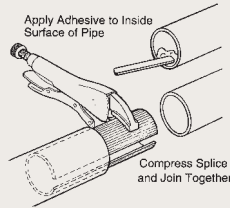

Tee Fittings

To attach the tee fitting to the post, a self tapping, stainless steel, hexagon head screw with lockwasher is positioned through the fitting and threaded into the 7/32" hole in the tubular post.

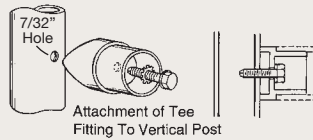

When two 90° tees are located directly opposite each other to form a cross, a stainless steel through bolt, lockwasher and nut are used.

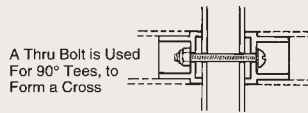

Mounting Options

Pipe or picket railing can be embedded in concrete and grouted, or mounted on decks and platforms with base flanges, or side-mounted on fascia or stringer by means of fascia flanges.

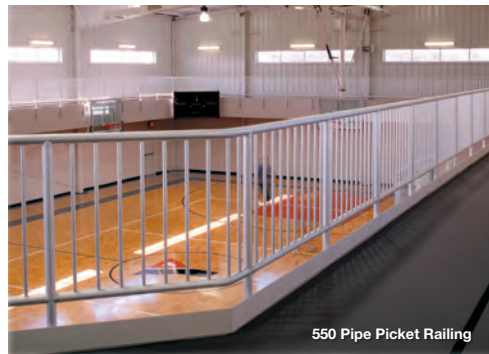
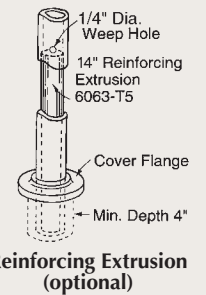
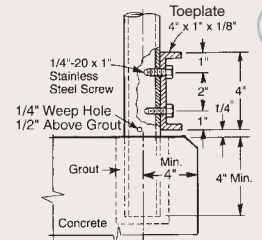
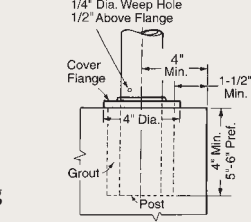
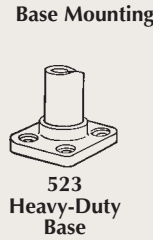
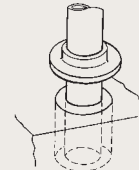

TECHNICAL SUPPORT -

For continuous spans in excess of 40 feet, expansion joints should be provided. To make an expansion joint, one end of the spliced joint should not have structural adhesive applied so that it is free to move in or out of the pipe. If a joint is provided every 30 feet, the width of the gap should allow 1/8" expansion for each 40°F of expected temperature rise. All pipe railing splices should be made no more than 12" from the nearest post.

MATERIALS -

All rails and posts shall be formed from extruded 6063-T6 aluminum of 1-1/2" Schedule 40 pipe size, except where there are formed elbows, whereby, 6063-T4 is used. All pickets are 3/4" round, formed from extruded 6063-T5 aluminum. All railing accessories shall be cast from ANSI 713 alloy. All fasteners used in the system shall be aluminum or stainless steel.

RIGIDITY -

Post spacing shall not exceed 6' 0" center-to-center. All posts will be unspliced single pipe length. Lower rails shall be a single unspliced length between posts. All top rails shall be continuous whenever possible. All fasteners shall be tightened so that

completed railing is rigid and free of play at joints and component attachments.

WORKMANSHIP -

All pipe cuts shall be square and accurate for minimum joint-gap. Cuts shall be clean and free of chamfer, from deburring, nicks and burrs. Holes shall be drilled the proper size for a tight flush fit of rivets and screws. All posts grouted in concrete must have one 1/4" diameter weep hole, 1/2" above post collar, in the plane of the rail.

SCOPE OF WORK -

Superior Aluminum Series 500 railing meets federal safety requirements as determined by an independent testing laboratory. Test results available upon request.

Superior Aluminum Products, Inc.

555 East Main • P.O. Box 430 • Russia, OH 45363
937-526-4065 • Fax: 937-526-3904

info@superioraluminum.com • www.superioraluminum.com